

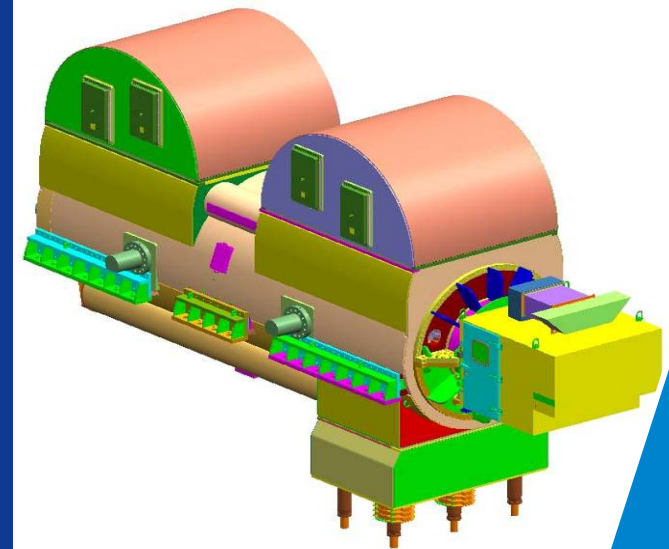

2 Pole 1222MVA Turbo-Generator & 4 Pole 1690MVA Turbo-Generator



27. August, 2008
Generator Design Team
Chong Whie Cho

2008 CIGRE SESSION 42, Paris

- **Introduction**

- **2-Pole 1222MVA Generator**
 - Specifications
 - Issues from up-rate
 - Conceptual design cases
 - Electrical loadings
 - Design risks
 - Main design features

- **4-Pole 1690MVA Generator**
 - Specifications
 - Electrical loadings
 - Design risks

- **Conclusion**

Introduction

- **Needs:**
 - **Ultra Super Critical Power Plant**
 - **Increasing Plant Efficiency and Power output**
 - **Bigger generator is required.**

- **Largest generator design:**
 - **High Voltage , High Current , High Flux, High Ampere Turn Loading require the larger machine diameter, longer machine length, more efficient cooling.**
 - **Use the existing model for machine reliability.**
 - **Adoption of well-evaluated design technology.**
 - **All generator component engineering should be performed.**
 - **General Electric Company's Experiences for machine reliability.**

2-Pole 1222MVA Generator

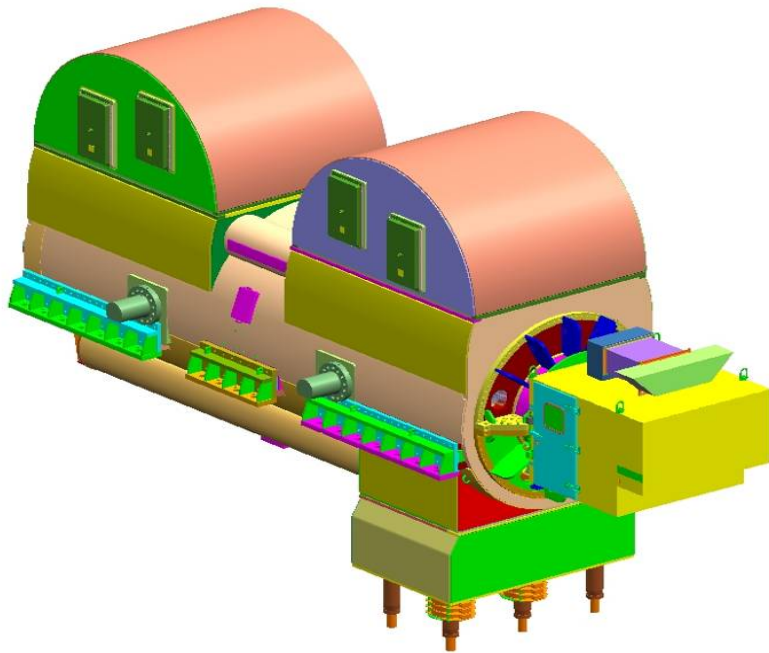

▪ Specifications of 2-Pole 1222MVA Generator

- No. of Poles : 2
- Operating Frequency : 60 Hz
- Rated MVA : 1222 MVA
- Rated MW: 1100 MW
- Power Factor : 0.9
- Terminal Voltage (kV) : 30
- Terminal Current (A) : 23521
- Internal Hydrogen Press. (Psig) : 75
- Stator Winding Cooling System : Direct H₂O
- Rotor Winding Ventilation System : Direct H₂ Diagonal Flow

Issues from up-rate

Parameter	Result		
Voltage ↑	Phi ↑	Series Turn ↑	
Current ↑	Mar ↑	Circuit ↑	
Phi ↑	Core Volume ↑	Material Cost ↑	Efficiency ↑
Mar ↑	Field MMF ↑ , Rotor Dia. ↑	Cooling Cost ↑	Efficiency ↓
Series Turn ↑	Phi ↓	Mar ↑	No. of Slot ↑ Manufacturing M/H ↑ Key Bar Cost ↑

- Design Difficulties

Terminal Voltage, Terminal Current, Flux, Armature Reaction, Field Voltage/Current are close to design experience.

- Design Goal

Higher Voltage vs. Larger Current

Larger Flux vs. Larger Armature Reaction

Volume vs. Cost vs. Experience

Re-distribution of Electrical vs. Mechanical Vs. Thermal loads

} => Iterative Trade-Off

Conceptual design cases

▪ Up-rating Case Studies :

Item	Ref. Model	Case A	Case B	Case C	Case D
Apparent Power (MVA)	978	1222	1222	1222	1222
Core Diameter (%)	100.0	106.7	108.6	106.7	104.8
Rotor Diameter (%)	100.0	100.9 (Within Exp.)	103.0	100.9 (Within Exp.)	100.9 (Within Exp.)
Rotor Length (%)	100.0	112.4	107.8	112.4	112.4
Armature Voltage (kV)	25	30	30	27	18
No. of Circuits	2	2	2	3	4

Electrical loadings

▪ Electrical Loading Comparison : (Case A)

Item	Ref. Model	1222MVA Model	Remarks
Rated MVA	100.0	124.9	
Phi (%)	100.0	120.0	< Mach. Exp.
M _{ar} (%)	100.0	104.1	Similar
Bar Force (%)	100.0	121.2	< Design Guide
Field Voltage (%)	100.0	107.4	< Design Guide
Field Current (%)	100.0	115.4	< Design Guide
Core Outer Dia. (%)	100.0	106.7	< Mach. Exp
Core Length. (%)	100.0	112.4	< Mach. Exp
Rotor Outer Dia. (%)	100.0	100.9	Similar/Mach. Exp
D ² L/kVA (%)	100.0	102.4	

Design risks

▪ Up-rating Risk Studies :

Risks	Priority	Counterproposal Design
Insulation Failure -Due to Coolant Leak & 30kV terminal Voltage.	4	Installation of Coolant Leakage Monitor Reduced Brazing Points and Induction Brazing Implement of a first piece qualification plan Stator Bar Prototype Test More reliable Insulation & Gradient System
Rotor Vibration	4	Reduce Field Temperature Modify Bearing Span High Speed Balancing & Factory Running Test
Stator Frame Vib.	3	3-D Vibration Analysis Ref. Model Field Operational Data First Unit Verification Test
Reliability due to limited factory test	3	First Unit Verification Test Factory Running Test
Cost Reduction	2	Reduce bearing span Reduce number of key bars

Main design features

▪ Diagonal Flow Ventilation System

- Efficient and well-proven design for generator ventilation system
- Adoption of diagonal flow ventilation system

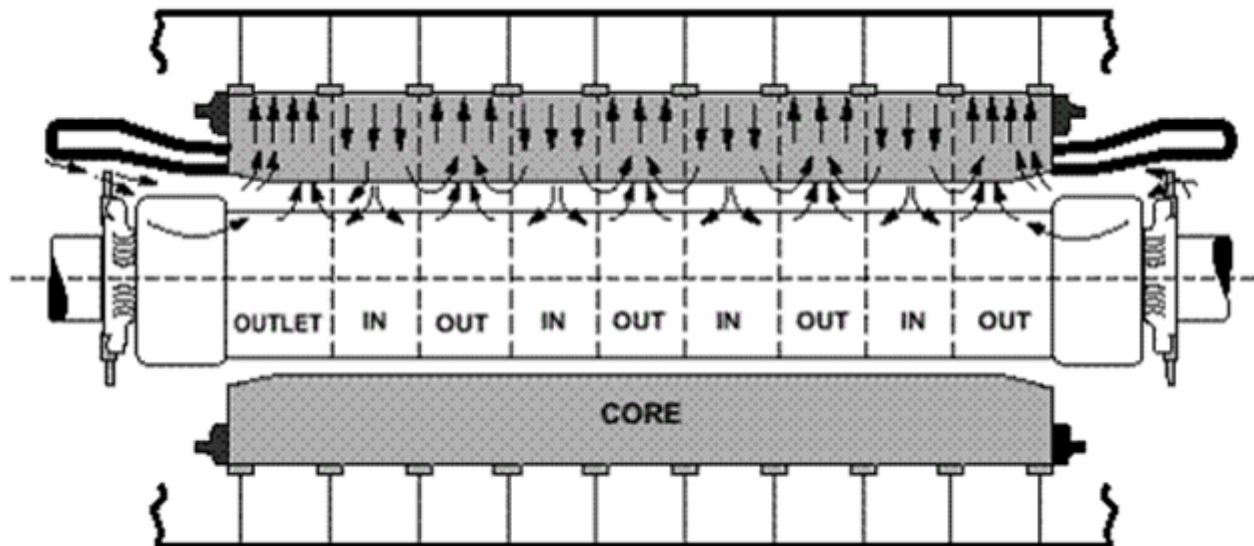

Main design features

▪ Stator Frame and Stator Core Vibration Suspension System

- Vibration Separation between stator core and stator frame is required.
- Adoption of well-evaluated key and spring bar system.

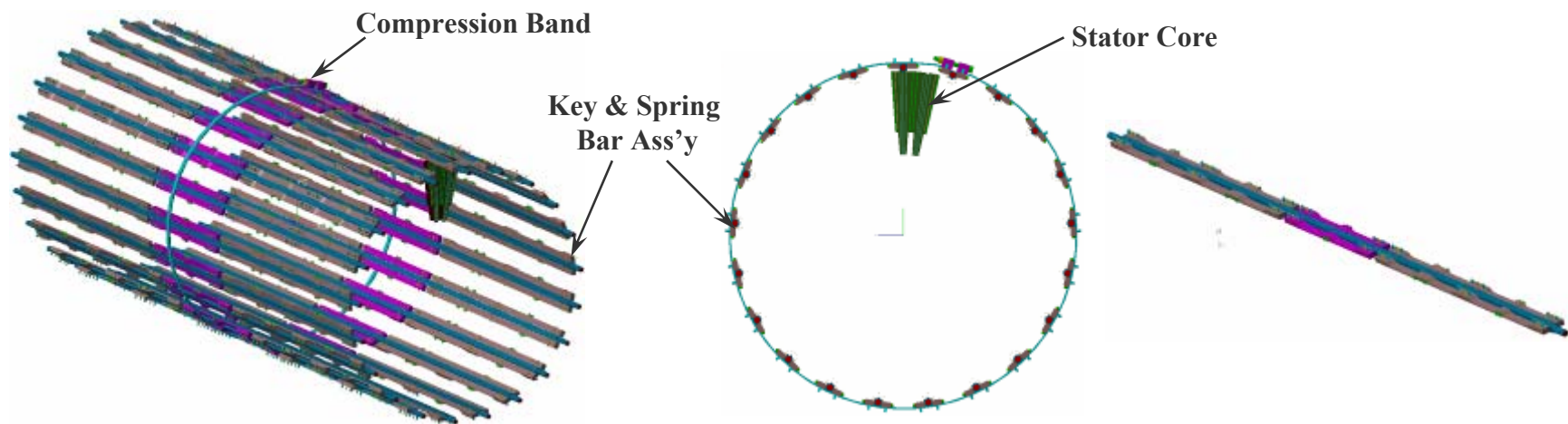

Main design features

▪ End Winding Support System

- Allowance of thermal expansion
- Long term Tightness without looseness
- Resistant to 3 phase sudden short circuit force
- For Easier Maintenance
- Well-evaluated General Electrics Tetra-lock End Winding Support System

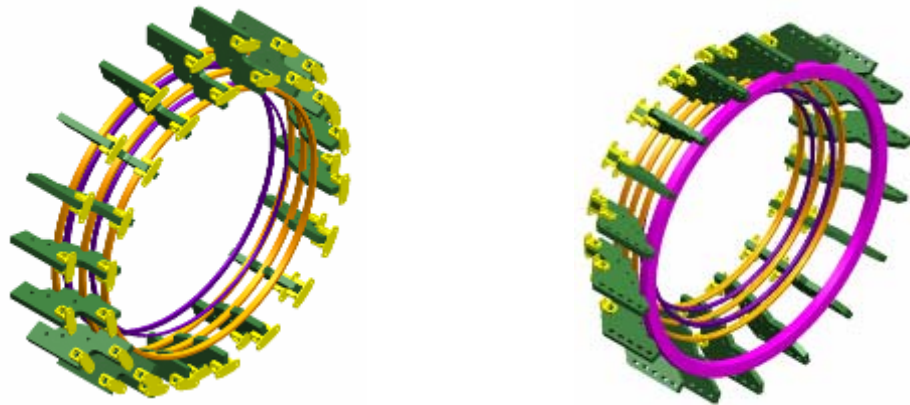

Main design features

▪ Separated Single-Pass Water Cooled Stator Winding

- With the up-rated output, efficient stator winding cooling system is needed.
- The lower stray load loss and lower coolant flow rate.
- Narrower slot dimension for smaller core outer diameter within machine experience.
- The stator winding and phase connection ring are cooled separately.

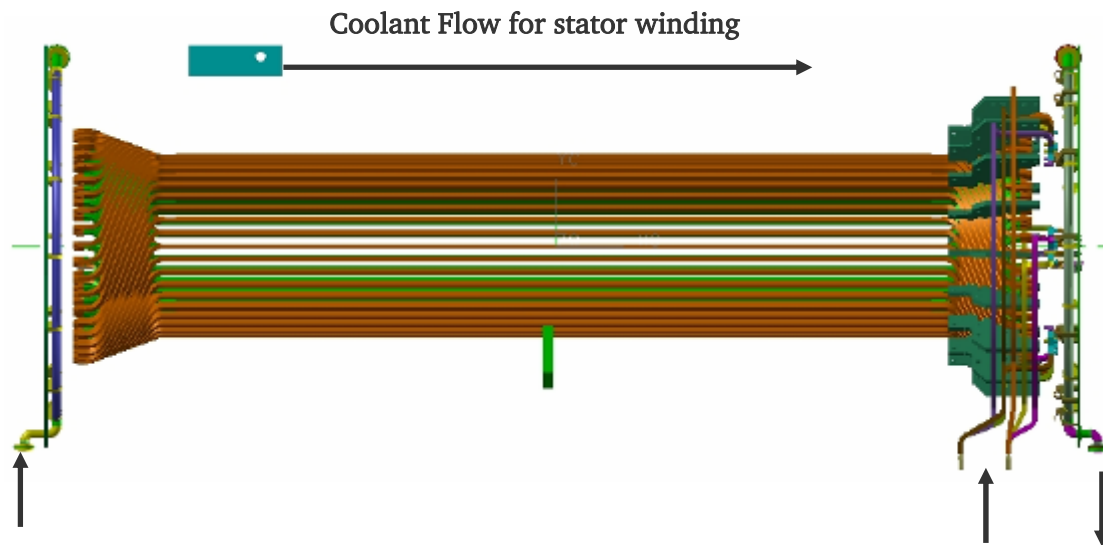

Main design features

▪ Fan Analysis

- For the machine reliability, efficient ventilation system is required.
- Need for Efficient Ventilation Design before manufacturing.
- Determination of Fan Performance to ensure the required fluid volume and ventilation system
- Determination of Fan Specification from operating model.
- Advance fluid analysis with complete 3-D models.
- Final decision of Fan Specification.
- Fan performance test will be done.

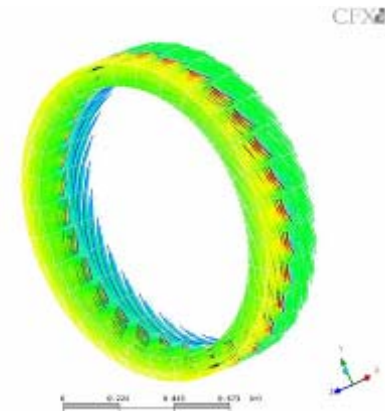
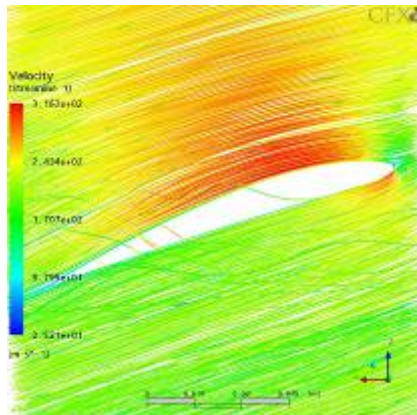
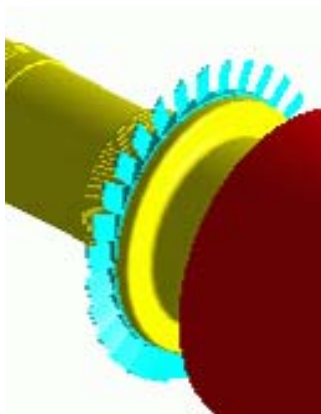

Main design features

▪ Evaluation of Rotor Vibration and Stress

- From the longer rotor length compare to the ref. model, rotor dynamic characteristic should be evaluated.
- Single Span Rotor Dynamic Analysis using internal technology is applied.
- Analysis indicated the result to be within the design limit.

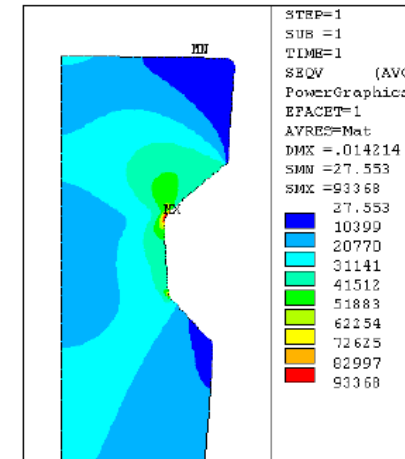
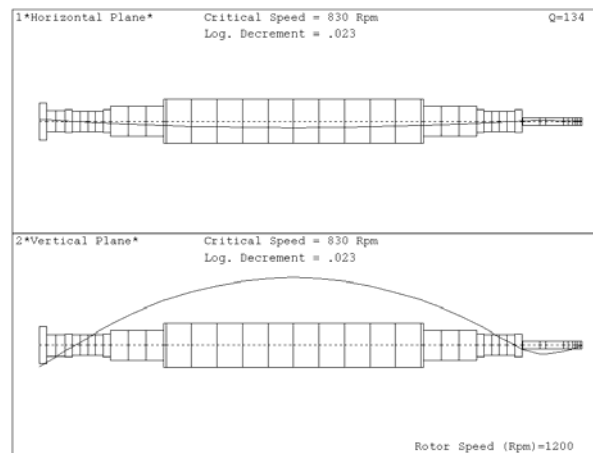
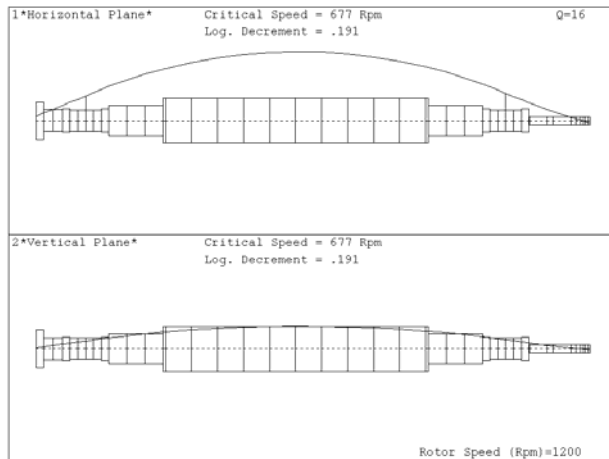

Main design features

▪ Stator and Stator Core Vibration

- Because of the increased size of the generator compare to the ref. model, stator frame stress and vibration are evaluated for machine reliability.
- Three dimensional stress and vibration analysis using ANSYS engineering analysis tool.
- Analysis indicated the result to be within the design limit.

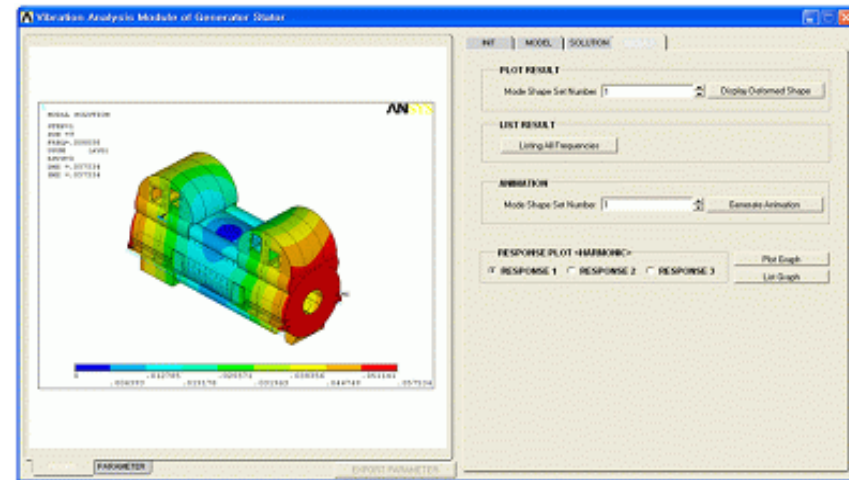
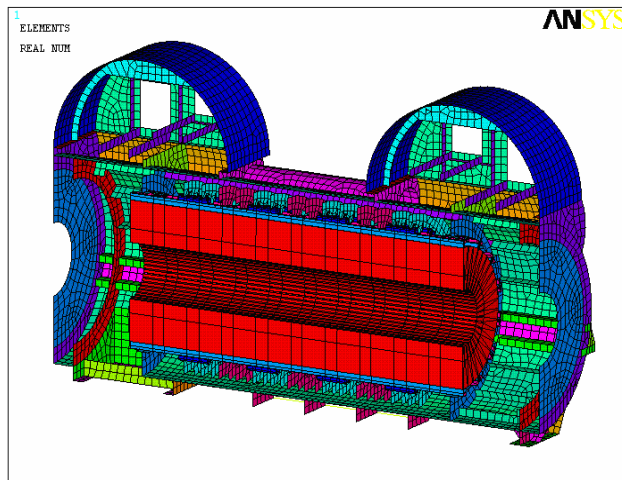

Main design features

▪ Stator Vibration Harmonic Analysis

- Because of the increased size of the generator compare to the ref. model, stator vibration harmonic analysis is evaluated for machine reliability.
- Three dimensional harmonic vibration analysis using ANSYS engineering analysis tool.
- Analysis under real operation condition.
- Analysis indicated that all the stator frame design factors are within the design limit.

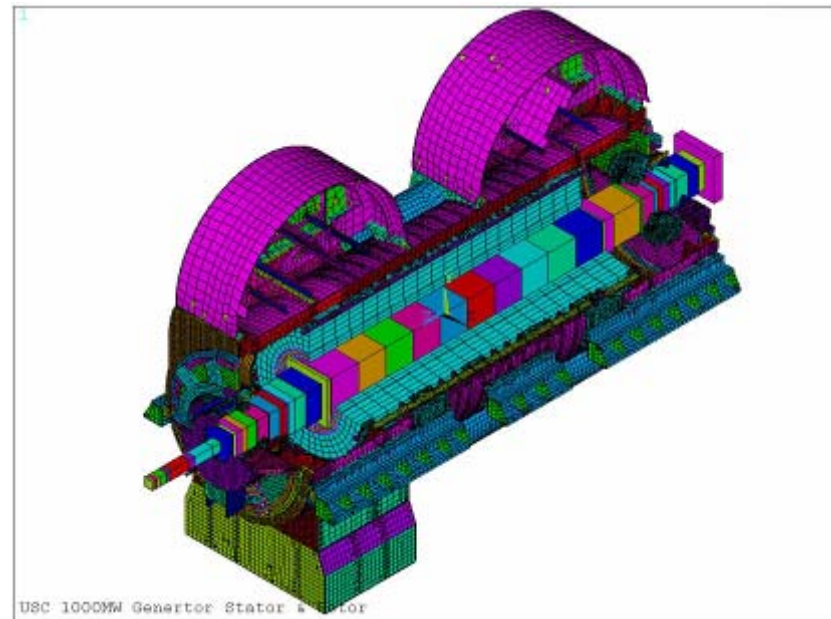

Main design features

▪ Evaluation of Field End Winding Temperature

- High Field Winding Ampere Turn Loading -> Increase in Field Winding Temp.
- Thermal analysis of rotor body and end winding.
- Study of thermal sensitivity.

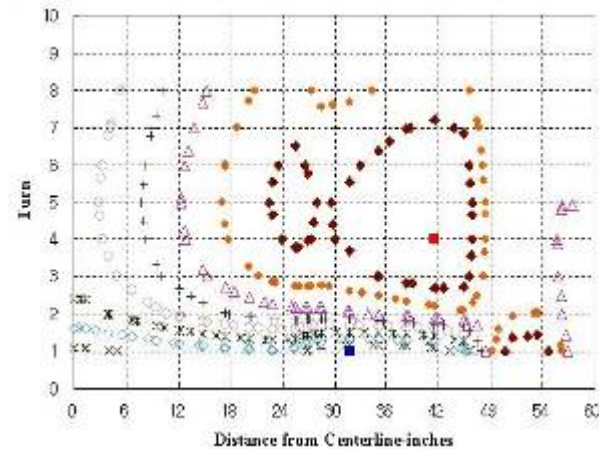
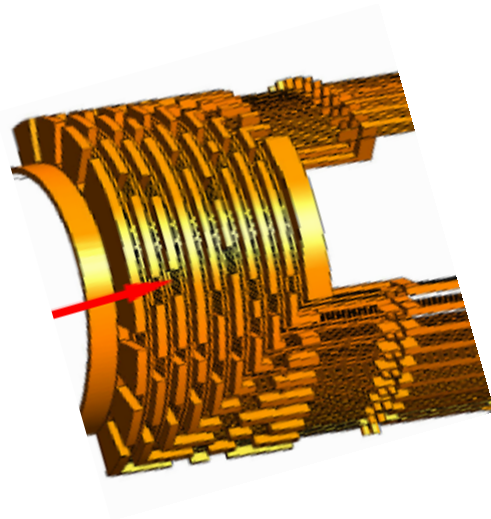

4-Pole 1690MVA Generator

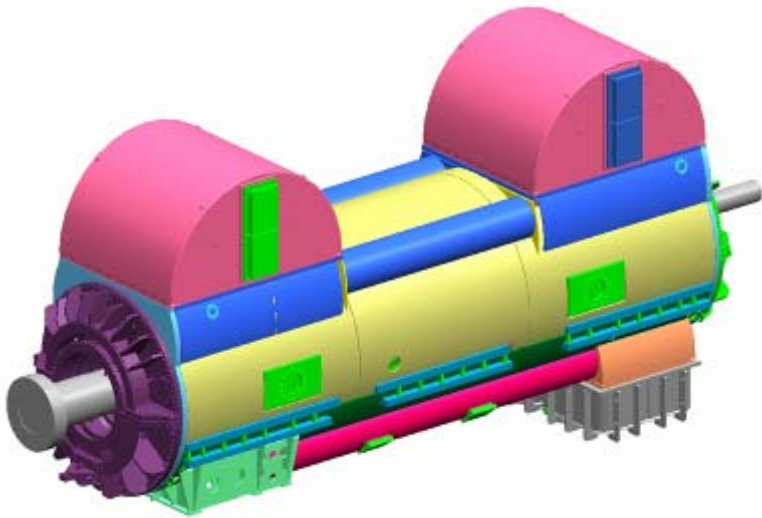

▪ Specifications of 4-Pole 1690MVA Generator

- No. of Poles : 4
- Operating Frequency : 60 Hz
- Rated MVA : 1690 MVA
- Rated MW : 1521 MW
- Power Factor : 0.9
- Terminal Voltage (kV) : 24
- Terminal Current (A) : 40655
- Internal Hydrogen Press. (Psig) : 75
- Stator Winding Cooling System : Direct H₂O
- Rotor Winding Ventilation System : Direct H₂ Radial Flow

Conceptual design

▪ Up-rating Studies :

Item	Ref. Model	Shinkori #3/4
Apparent Power (MVA)	1527.7	1690
Core Diameter (%)	100.0	100.0
Rotor Diameter (%)	100.0	100.0
Core Length (%)	100.0	100.0
Armature Voltage (kV)	24	24
No. of Circuits	4	4

Electrical loadings

- **Electrical Loading Comparison :**

Item	Ref. Model	1690MVA Model	Remarks
Rated MVA	100.0	110.6	
Phi (%)	100.0	100.0	Same
M _{ar} (%)	100.0	110.6	< Exp.
Bar Force (%)	100.0	114.0	< Exp.
Field Voltage (%)	100.0	120.2	< Exp.
Field Current (%)	100.0	102.3	Similar
Core Outer Dia. (%)	100.0	100.0	Same
Core Length. (%)	100.0	100.0	Same
Rotor Outer Dia. (%)	100.0	100.0	Same
D ² L/kVA (%)	100.0	90.4	

Design risks

▪ Up-rating Risk Studies :

Risks	Priority	Counterproposal Design
Over Forging Manufacturing Capa. -Weight	5	Increasing Power Density
Over Machining Capacity -Weight	5	
Over Turning Machining Capa. & Heat Treatment Facility -Length	5	Application of Stub Shaft
Over High Speed Balancing Capa. -Weight	4	Design Modification
Close to Crane Handling Capa. -Length & Weight	4	Handling Capacity Test
Large Current	2	Liquid Cooled Terminal Box, New CT, New HVB

Development of 2-Pole 1222MVA Generator.

- DOOSAN Heavy Industries & Construction under co-operation with General Electric has completed the design of 2-pole 1222MVA generator for fossil power plant.
- 2-pole 1222MVA generator will be manufactured in a short period.
- Verification test and factory running test for first implementation will be conducted.

Development of 4-Pole 1690MVA Generator.

- DOOSAN Heavy Industries & Construction is up-rating the existing 4-pole generator model up to 1690MVA.
- 4-pole 1690MVA generator are planned to be installed in Shinkori #3/4 nuclear power plant
- Factory tests and field test for machine will be conducted.

Thank you

Presenter

Chong Whie Cho

chongwhie.cho@doosan.com

