

# What is the largest unit capacity of turbine generator ?



Makoto TARI  
**vonRoll**

*Replica of Thomas Edison's First Incandescent Lamp  
1879 (date of the original)*

CIGRE 2008 Group A1 Giga-Watt Generation Panel Session

# Origin of Generators

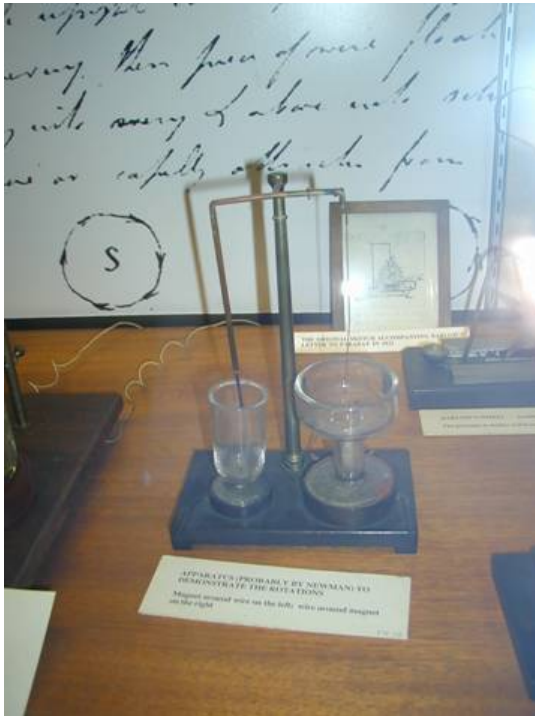

M. Faraday



A. H. Pixii 1832

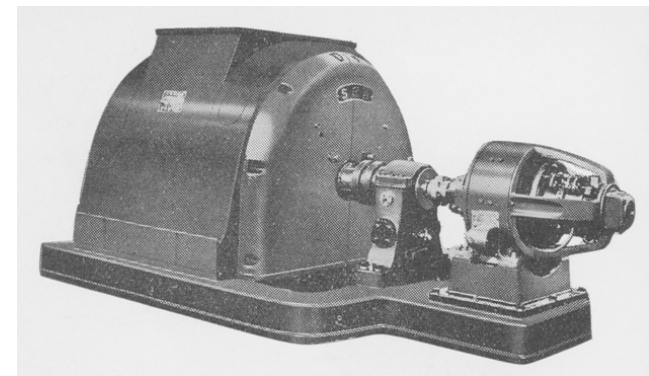

1800's

# Now! 2 pole 1,000 ~1,200MW generators under manufacturing & operation



Under assembly of 1000MW gen  
2 pole – 60Hz – 3,600min<sup>-1</sup>

# How to realize huge power plant ?

a) Tandem Compound type  $3000\text{min}^{-1}$  &  $3600\text{min}^{-1}$

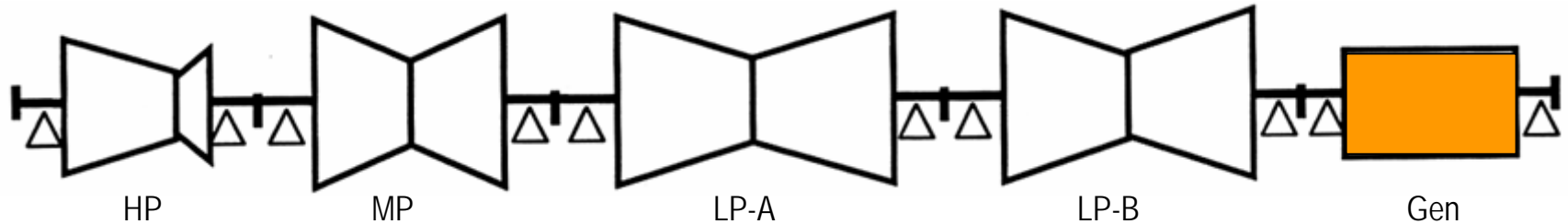

b) Cross Compound type  $3000/3000\text{min}^{-1}$  or  $3000/1500\text{min}^{-1}$ 、 $3600/1800\text{min}^{-1}$

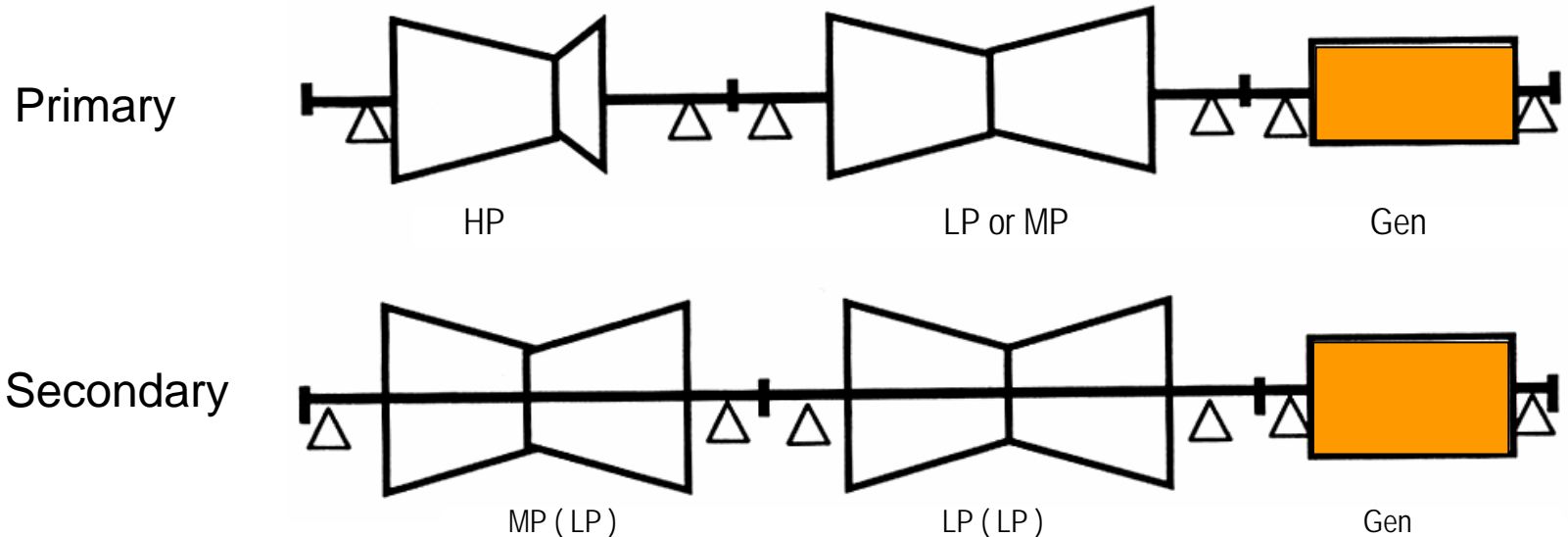

# 50Hz - 1,000MW CC type plant

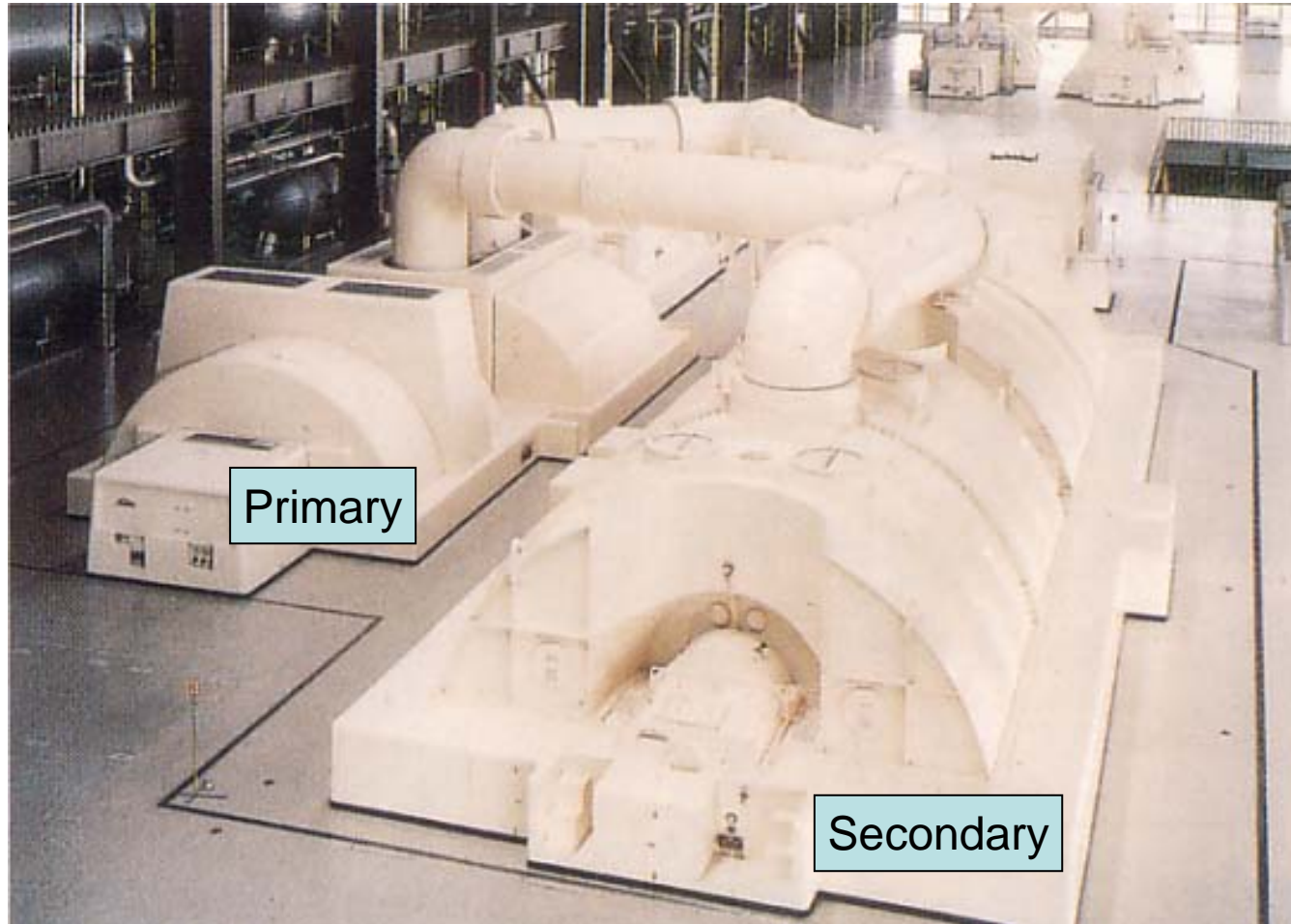

# 2p-60Hz-3,600min-1,000MW TC type plant



# What is Key component ?

## Large sized Retaining Ring !

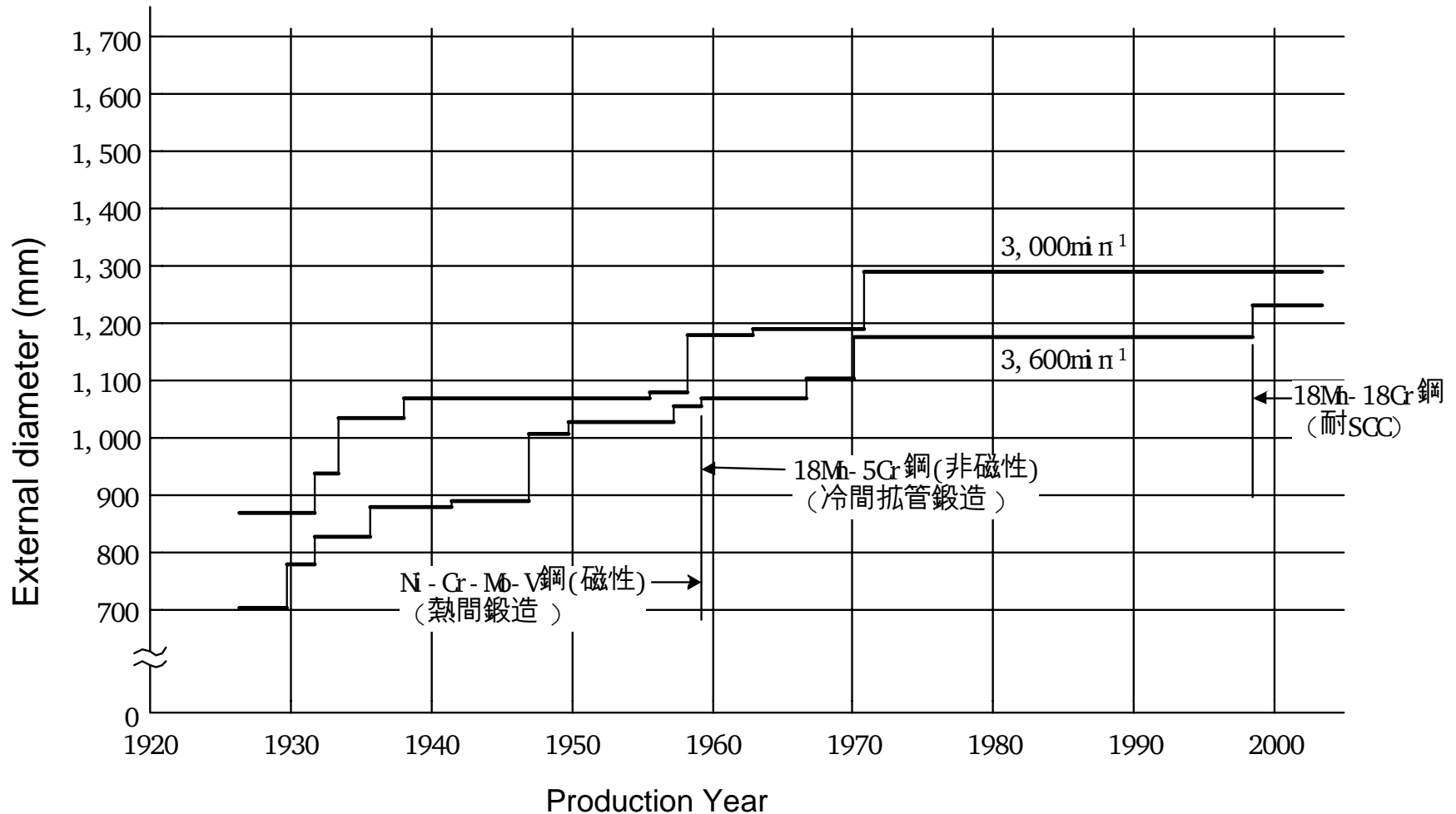

# What is Key technology ?

## Stable Rotor Running without vibration problem !

Critical Speed depending on Rot Diameter / Length (L/D)

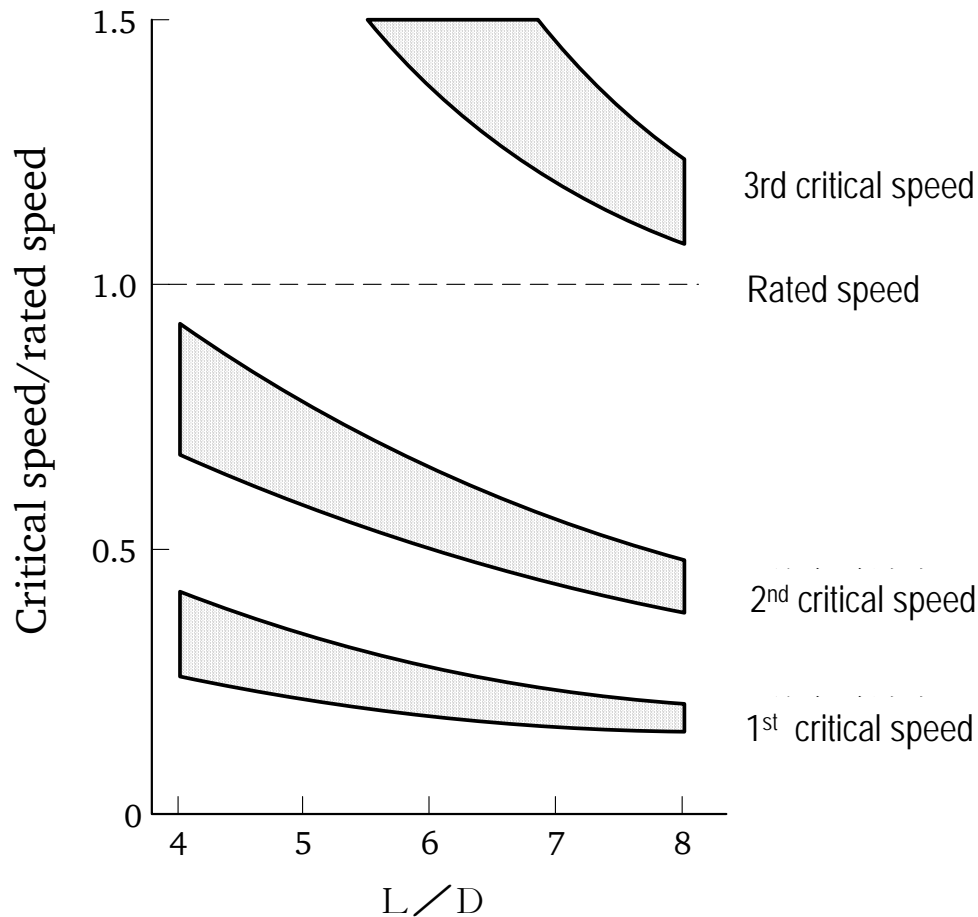

# Possible largest 2pole-60Hz generator?

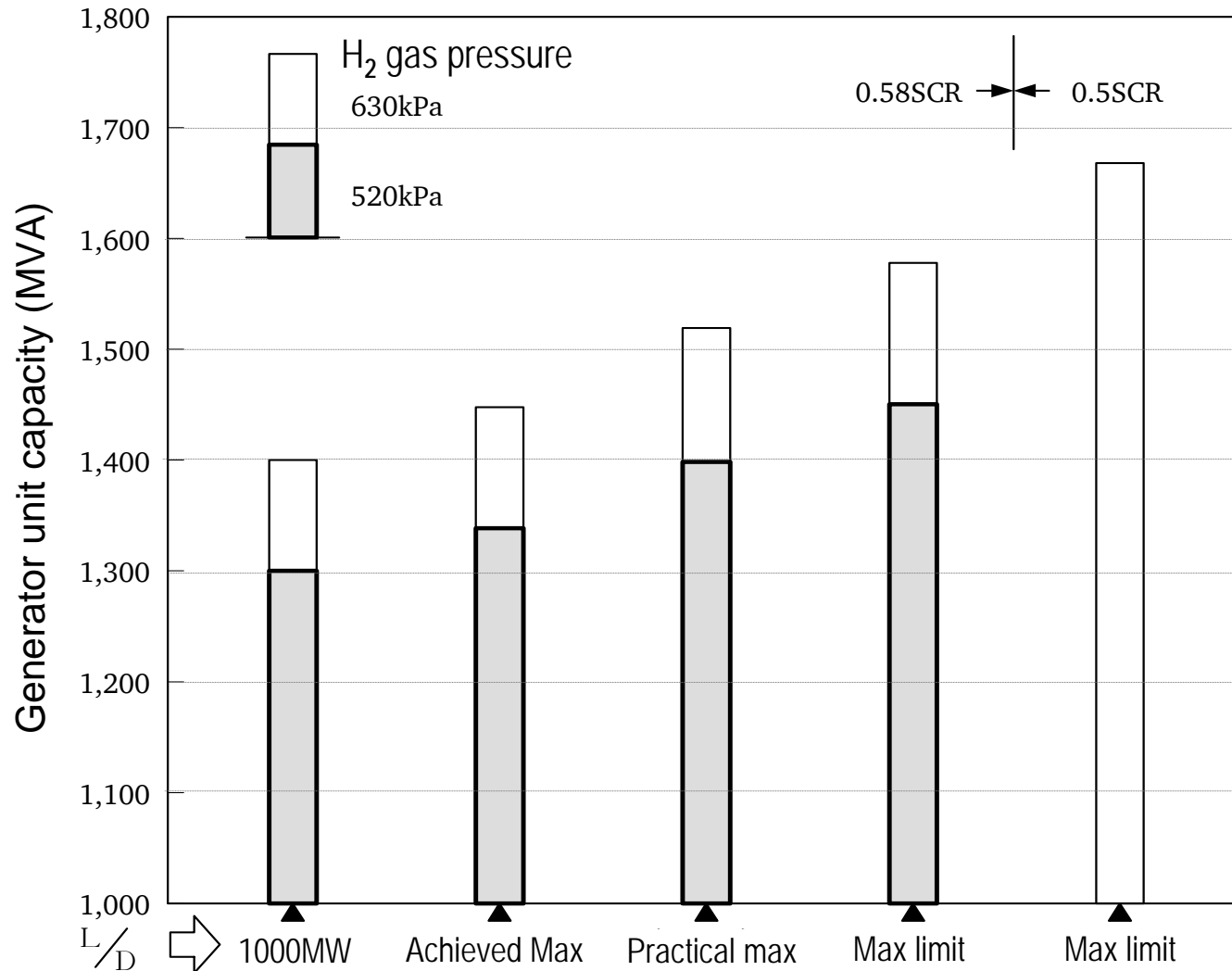

# Expected Max Turbine and Generator Unit Capacity, and Technical issues to be solved

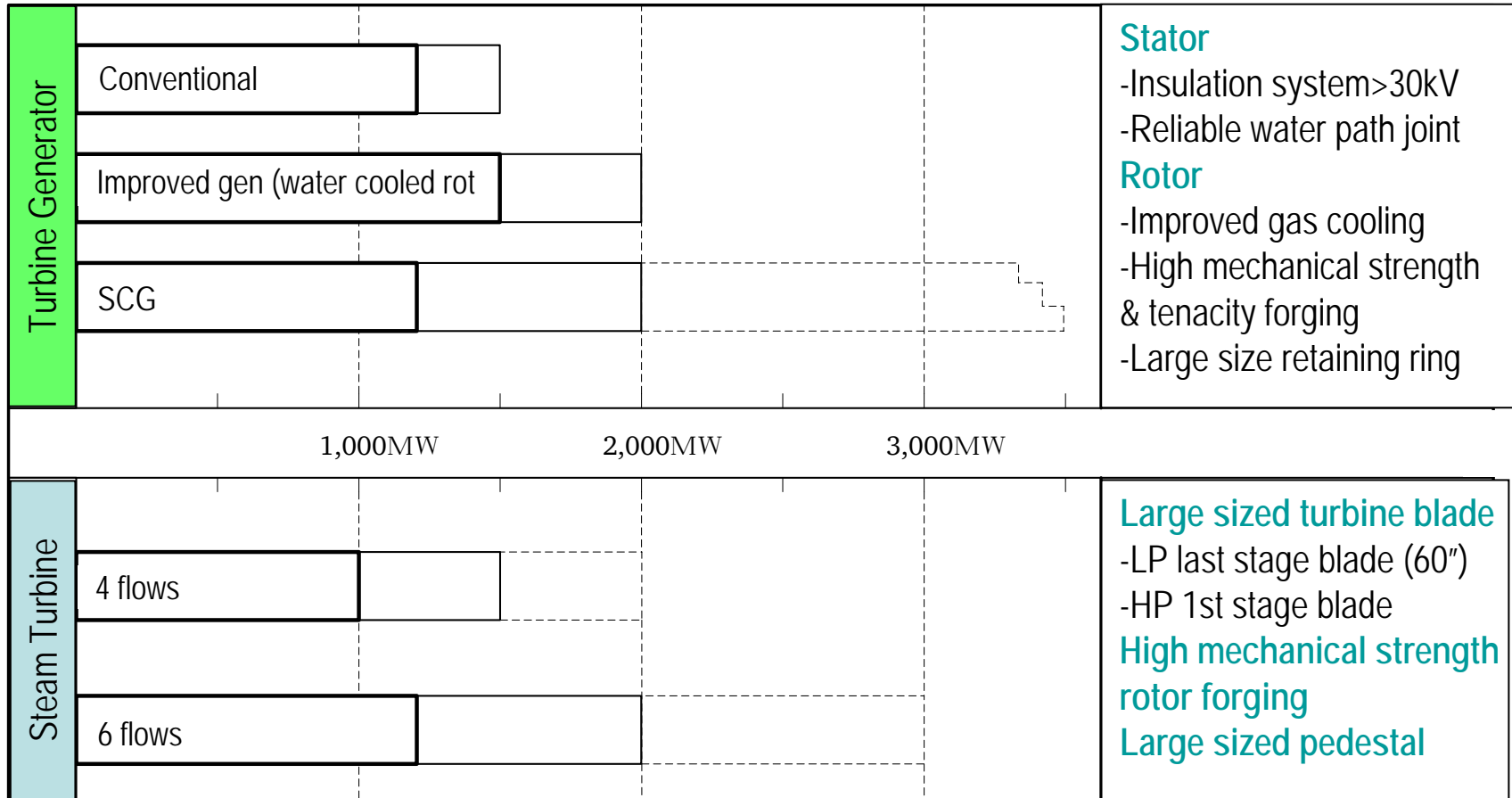

- Stator**
- Insulation system >30kV
  - Reliable water path joint
- Rotor**
- Improved gas cooling
  - High mechanical strength & tenacity forging
  - Large size retaining ring

- Large sized turbine blade**
- LP last stage blade (60")
  - HP 1st stage blade
- High mechanical strength rotor forging**
- Large sized pedestal**

Existing technology    Improved technology    New/improved technology